

[CONTRIBUTION FROM THE DEPARTMENT OF BIOCHEMISTRY, THE UNIVERSITY OF WISCONSIN]

***cis-trans* Enolic  $\beta$ -D-Glycosides of Methyl Acetoacetate<sup>1</sup>**

BY CLINTON E. BALLOU AND KARL PAUL LINK

Glucosides of simple enols may exist in two forms (in addition to the usual  $\alpha$ - $\beta$  isomers), the consequence of *cis-trans* isomerism in the aglucon.<sup>2</sup> The condensation of tetraacetyl- $\alpha$ -D-glucopyranosyl bromide with ethyl acetoacetate by the modified Robertson method<sup>3</sup> produced two enolic  $\beta$ -D-glucopyranoside tetraacetates. Attempted deacetylation of these compounds by the catalytic barium methoxide method<sup>4</sup> gave uncrystallizable sirups, most likely due to partial ester interchange of the aglucon with the solvent (methanol).<sup>2</sup>

In this paper we are reporting certain improvements and modifications in the method which have resulted in the synthesis of the *cis-trans* enolic tetraacetyl- $\beta$ -D-glucopyranosides of methyl acetoacetate, and the successful deacetylation of these compounds to give crystalline derivatives. The *cis-trans*  $\beta$ -D-galactopyranosides,  $\beta$ -cellobiosides and one  $\beta$ -D-xylopyranoside were also prepared.

*cis-trans* Configurations had been arbitrarily assigned to these derivatives on the basis of physical properties.<sup>2</sup> The higher melting and the less soluble of the pair was designated *trans*(?). The present study has revealed the inadequacy of that procedure, and attempts to assign configurations on a more sound basis.

The glucopyranosides and galactopyranosides of methyl acetoacetate have melting points as shown in Table I. Of each pair, the higher melting acetylated derivative has a very low solubility in ether, while the lower melting one is much more soluble in that solvent. The deacetylated compounds show the same solubility characteristics toward absolute ethanol. On the basis of these properties, the glucoside I and the galactoside V would have identical configurations in the aglycon, *trans*(?), while II and VI would be *cis*(?).

and Hudson.<sup>5</sup> When the deacetylated *cis-trans* pairs, III, IV, and VII, VIII, were subjected to periodate oxidation, the asymmetry due to carbon atoms 2, 3 and 4 of the hexose portion was destroyed. Thus, the glucopyranoside and galactopyranoside with the same configuration in the aglycon should give the same dialdehyde (L'-alkoxy-D-hydroxymethylidiglycolic aldehyde in which the alkoxy group is *cis* or *trans* enolic methyl acetoacetate.)

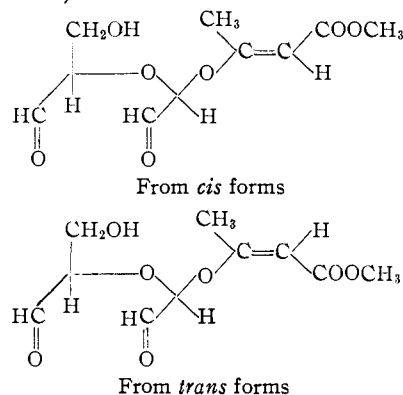

These products correspond to L'-methoxy-D-hydroxymethylidiglycolic aldehyde formed in periodate oxidation of methyl  $\beta$ -D-glucopyranoside. The results are shown in Fig. 1. The products were not isolated, but the final rotations of the reaction mixture in each periodate oxidation show that III and VIII (and subsequently I and VI) have the same aglycon configuration. By the same analogy IV and VII (likewise II and V) possess identical aglycon configurations.

The acetylated glucopyranosides and galactopyranosides all possess comparable specific rota-

TABLE I  
ANALYSES AND CONSTANTS OF METHYL ACETOACETATE GLYCOSIDES

	Methyl acetoacetates	M. p., °C.	[ $\alpha$ ] <sub>D</sub> <sup>20</sup>	Crystd. from	Analyses, %			
					Calcd. C	H	Found C	H
I	<i>trans</i> -O-(Tetraacetyl- $\beta$ -D-glucopyranosyl)	132-133.5	-26.6° (c, 3, CHCl <sub>3</sub> )	Ether	51.21	5.85	51.10	6.14
II	<i>cis</i> -O-(Tetraacetyl- $\beta$ -D-glucopyranosyl)	125-126	-23.7° (c, 2.5, CHCl <sub>3</sub> )	Ether-pet. ether	51.21	5.85	51.30	5.99
III	<i>trans</i> -O-( $\beta$ -D-glucopyranosyl)	186-187	+43.6° (c, 2, H <sub>2</sub> O)	MeOH-ether	47.50	6.48	47.40	6.71
IV	<i>cis</i> -O-( $\beta$ -D-glucopyranosyl)	143-145	-92.3° (c, 3, H <sub>2</sub> O)	MeOH-ether	47.50	6.48	47.47	6.50
V	<i>cis</i> -O-(Tetraacetyl- $\beta$ -D-galactopyranosyl)	152-153	-3.5° (c, 6, CHCl <sub>3</sub> )	Ether	51.21	5.85	51.10	5.96
VI	<i>trans</i> -O-(Tetraacetyl- $\beta$ -D-galactopyranosyl)	142-144	-17.9° (c, 3, CHCl <sub>3</sub> )	Abs. EtOH	51.21	5.85	51.13	5.97
VII	<i>cis</i> -O-( $\beta$ -D-galactopyranosyl)	188-189	-75.7° (c, 2, H <sub>2</sub> O)	Abs. EtOH	47.50	6.48	47.70	6.67
VIII	<i>trans</i> -O-( $\beta$ -D-galactopyranosyl)	160-161	+83.1° (c, 2, H <sub>2</sub> O)	Abs. EtOH	47.50	6.48	47.25	6.71
IX	<i>cis</i> -O-(Heptaacetyl- $\beta$ -cellobiosyl)	194-196	-30.1° (c, 1, CHCl <sub>3</sub> )	MeOH	50.80	5.72	50.50	5.80
X	<i>trans</i> -O-(Heptaacetyl- $\beta$ -cellobiosyl)	187-188	-25.7° (c, 2, CHCl <sub>3</sub> )	Abs. EtOH	50.80	5.72	50.70	5.92
XI	<i>cis</i> -O-( $\beta$ -cellobiosyl)	218-220 (dec.)	-76.9° (c, 2, H <sub>2</sub> O)	Water-EtOH	46.40	6.37	46.45	6.58
XII	<i>trans</i> -O-( $\beta$ -cellobiosyl)	175-177	+28.2° (c, 2, H <sub>2</sub> O)	Abs. EtOH	46.40	6.37	46.20	6.48
XIII	<i>cis</i> -O-(Triacetyl- $\beta$ -D-xylopyranosyl)	144-146	-44.6° (c, 2, CHCl <sub>3</sub> )	Ether	51.35	5.89	51.30	6.03
XIV	<i>cis</i> -O-( $\beta$ -D-xylopyranosyl)	183-185	-46.1° (c, 1.5, H <sub>2</sub> O)	Abs. EtOH	48.40	6.45	48.10	6.70

The true relationships were established by the periodate oxidation method as used by Jackson

(1) Published with the approval of the Director of the Wisconsin Agricultural Experiment Station. Supported in part by the Research Committee of the Graduate School from funds supplied by the Wisconsin Alumni Research Foundation.

(2) Ballou and Link, *THIS JOURNAL*, **72**, 3147 (1950).

(3) Huebner, Karjala, Sullivan and Link, *ibid.*, **66**, 906 (1944).

(4) Isbell, *J. Research Natl. Bur. Standards*, **5**, 1185 (1930).

tions, the values ranging from -3.5 to -26.6° in chloroform. Compounds I and VI are slightly more levorotatory. Upon deacetylation, however, very significant changes occur (Fig. 2). Compounds I and VI become rather strongly dextro-rotatory, while II and V become more strongly levorotatory. The molecular rotations of the *cis*-

(5) Jackson and Hudson, *THIS JOURNAL*, **59**, 994 (1937).

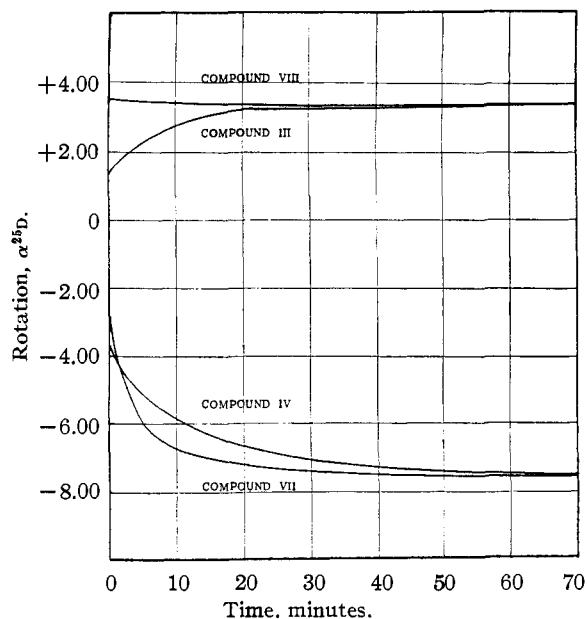

Fig. 1.—Rotatory change of aqueous solutions of the methyl acetoacetate glycosides during periodate oxidation.

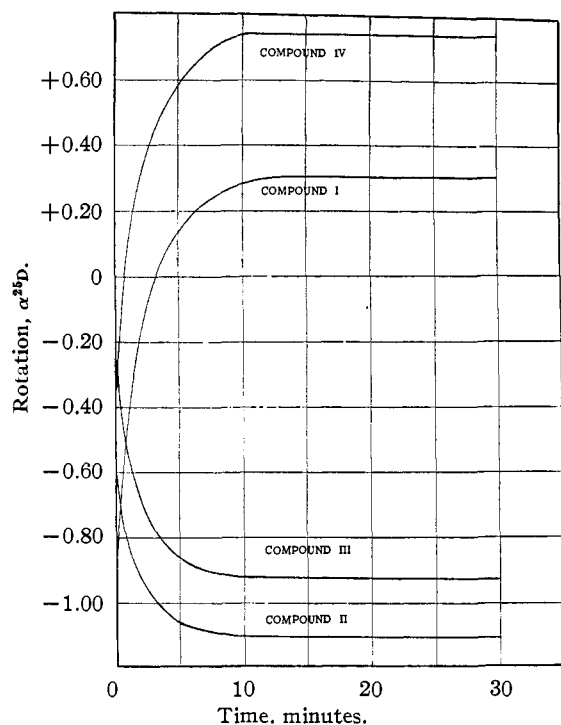

Fig. 2.—Rotatory change during deacetylation of methyl acetoacetate glycoside tetraacetates.

*trans* pairs are listed in Table II. In general, the molecular rotations of  $\beta$ -D-glycosides have values of  $-5000$  to  $-25000^{\circ}$ ,<sup>6</sup> and the few exceptions (*o*-nitrophenyl  $\beta$ -D-glucopyranoside tetraacetate, for example  $(M)_D + 21,100$ ) are characterized by having very high temperature coefficients.<sup>7</sup> The evidence indicates that these compounds undergo intramolecular association of the aglycon portion with a group in the sugar molecule.

(6) Pigman and Goepp, "Chemistry of the Carbohydrates," Academic Press Inc., New York, N. Y., 1948, pp. 85-88.

(7) Pigman, *J. Research Natl. Bur. Standards*, **33**, 129 (1944).

Compound	Rotation $(M)_D$	Solvent	Concn. %
Glucoside I	-11850	Chloroform	3
II	-10580	Chloroform	2.5
III	+12100	Water	2
	+8100	Methanol	0.5
	-19200	Acetic acid	1
	-18900	Dioxane	0.3
IV	-25700	Water	3
	-21200	Dioxane	0.3
Galactoside V]	-1570	Chloroform	6
VI	-8000	Chloroform	3
VII	-20500	Water	2
	-20400	Dioxane	0.3
VIII	+22800	Water	2
	-14200	Dioxane	0.3
Cellobioside IX	-22100	Chloroform	1
X	-18900	Chloroform	2
XI	-33800	Water	2
XII	+12400	Water	2

The change in specific rotation with temperature over the range from 5 to 75° was determined for some of the products described in this paper. The results are shown in Table III. Glycosides III and VIII have very high coefficients; the other two, IV and VII, show normal values in this same range. The abnormal temperature coefficients reported here are comparable with those found by Pigman for *o*-nitrophenyl  $\beta$ -D-glucopyranoside tetraacetates (a change of 18-20° specific rotation for the temperature range of 20-70°).<sup>7</sup> The change is toward a less dextrorotatory value, or a normal constant for  $\beta$ -D-glycosides.

Compound	Concn., g./100 ml.	<i>t</i> , °C.	$[\alpha]_D$ (water)
III	1.0680	3.0	+49.2
		20.0	+44.0
		44.0	+38.2
		73.0	+33.6
IV	0.8584	5.0	-92.8
		25.0	-92.1
		44.0	-90.5
		78.0	-90.8
VII	.8376	5.0	-76.2
		22.5	-75.8
		42.0	-75.1
		78.0	-76.2
VIII	.7820	4.0	+92.2
		22.0	+83.2
		44.5	+74.8
		75.5	+58.9

The effect of a solvent upon the optical rotation of a compound may often be related to the polarity of that solvent.<sup>8</sup> A solvent effect is readily observed with compounds III and VIII (Table II). The respective values in water,  $(M)_D + 12100$  and  $+22800$ , are contrasted with the normal values,  $(M)_D - 18900$  and  $-14200$ , observed in the

(8) Lowry, "Optical Rotatory Power," Longmans, Green and Co., New York, N. Y., 1935, p. 350.

non-polar solvent dioxane. Compounds IV and VII have normal rotations in both solvents. Thus, though the abnormal rotations of III and VIII may be related to a solvent effect, they are still correlated with some mutually shared structural quality.

Possible rationalizations for the abnormal rotations of compounds III and VIII may be considered. Were the effect due to steric hindrance, its occurrence would be more likely in the acetylated compounds which contain bulky substituents.<sup>7</sup> Also, it would not show such a pronounced solvent influence. If a polarization were involved, the rotation should become more abnormal in a solvent of low dielectric constant (dioxane).<sup>9</sup> The deacetylated derivatives possess, in the carbonyl group of the aglycon and the hydroxyl groups of the carbohydrate portion, the requisite structure for intramolecular bonding (XIX and XX).

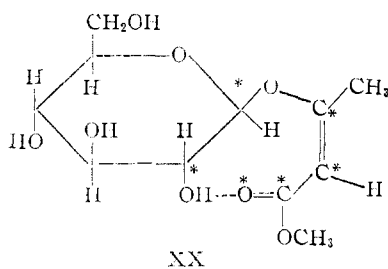
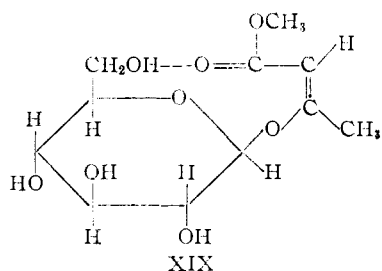

Such internally coordinated forms (XVII and XVIII) have been proposed for tartaric acid to explain its abnormal rotatory characteristics.<sup>10</sup>

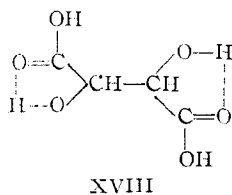
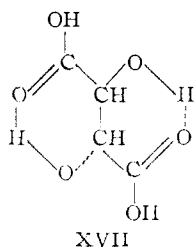

This type of interaction could account for the abnormal rotations of III and VIII. The influence of a polar solvent such as water, however, should be to decrease the contribution of such forms. According to Lowry,<sup>9</sup> one of the ways that the influence of the solvent is transmitted is by association "between a dipole in the optically active solute and another in the solvent," weakening "the field of force within the active molecule" and reducing "the contribution of the dipolar radical to the total optical activity of the molecule."

(9) Lowry, ref. 8, p. 351.

(10) Lowry and Burgess, *J. Chem. Soc.*, **123**, 2118 (1923); Lowry and Cutter, *ibid.*, **125**, 1468 (1924).

A partial answer may be obtained by a consideration of the parent substance acetoacetic ester. It exists in an enolic form (XXI) so stable that it may be isolated. This stability is thought to be

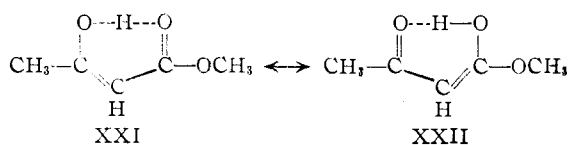

due to the fact that XXI may resonate as indicated. The chelate structures XXIII and XXIV can derive no stability from resonant forms which are completely compensated internally as are XXI

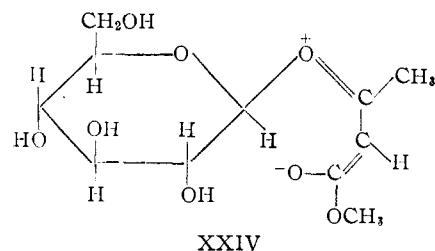
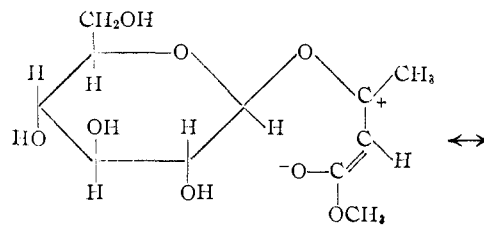
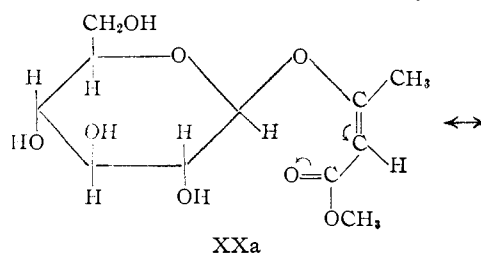

and XXII. That is, coordination as in XXIII or XXIV results in a separation of charge on the atoms indicated. Therefore, the contribution of these forms is probably small. The presence of water or alcohol may, on the other hand, materially increase their contribution by dissipation of this charge, and XXV then has the basic structure of XXII. Apparently the nucleophilic nature of

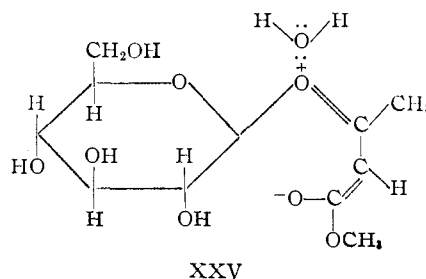

dioxane is insufficient to stabilize XXIV. Though association with the solvent would usually decrease intramolecular association, in this example it would tend to stabilize the internally coordinated

form. Such association could account for the dramatic effect of polar solvents on the rotation of these compounds. Structure XXV is an extreme form, of course, and the same effect may be adequately rationalized by XXa.

Chelate rings containing nine members must be proposed with caution, and they would not be expected to exhibit the stability found in six-membered rings. However, the chelate structures of carboxylic acids have as many as eight atoms involved.<sup>11</sup> The fact that six of the atoms in XX

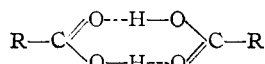

(indicated by asterisks) are partially fixed in space or restricted in rotation, may contribute to the probability of chelation.

Compounds III, IV, VII and VIII have failed to yield crystalline free acids. When they are dissolved in aqueous alkali, the rotation is observed to change as the ester is saponified. The two dextrorotatory derivatives, III and VIII, become strongly levorotatory upon saponification. This inversion is to be expected if the chelate structures XIX or XX actually exist. The free carboxyl group would itself be highly stabilized due to resonance, and the tendency for chelation in the free acid would be greatly decreased.

Inspection of molecular models of the *cis-trans* structures constructed from Hirschfelder atomic models, shows that the aglycon of the form with the methyl and carbomethoxy groups *trans* could easily bond with the hydroxyl group on carbon two or six of the sugar portion. The other form, methyl and carbomethoxy groups *cis*, holds the carbonyl group away from the hexose ring in an unfavorable position for bonding. This is apparent even from the perspective formulas. On the

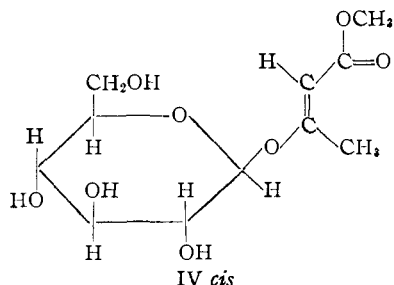
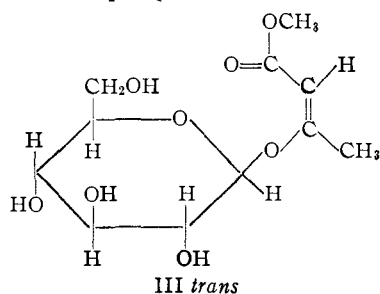

basis of intramolecular association, III and VIII (and subsequently I and VI) are assigned the *trans* configuration. The reference groups for this assignment are the methyl and carbomethoxy

(11) Gilman, "Organic Chemistry," John Wiley and Sons, Inc., New York, N. Y., 1943, p. 1868.

groups in the aglycon. The other glucoside (IV) and galactoside (VII), as well as II and V, may be assigned the *cis* configuration. Their rotations are normal in water indicating no appreciable interaction of the aglycon with the sugar portion, a fact more consistent with structure IV than III.

The high dextrorotation exhibited by compounds III and VIII is an unusual property for  $\beta$ -D-glucosides or galactosides.<sup>12</sup> As stated above, the evidence indicates that these abnormal rotations are related to some structural quality in common to the two compounds. This hypothesis is strengthened by the observation that the same abnormality is found in the  $\beta$ -cellobiosides of methyl acetoacetate (XI and XII). One form (XI) is normally levorotatory, while the other (XII) is dextrorotatory and has a high temperature coefficient.

Confirmatory evidence for the assigned relationships was obtained from a study of the ultraviolet absorption spectra of the enol glycosides due to the  $\alpha$ - $\beta$  unsaturated carbonyl structure. These data are given in Table IV. The *cis* forms all exhibit a maximum at about 232  $m\mu$ , while the *trans* forms have a maximum at 236  $m\mu$ . This difference in the wave length of the maxima is normal for *cis-trans* pairs.<sup>13</sup> There is seen to be complete correlation between structural assignment based on the rotation studies and the absorption spectra. Thus, one may classify other glycosides of methyl acetoacetate on the basis of the absorption spectrum. The one xyloside isolated is *cis*-O-(triacetyl- $\beta$ -D-xylopyranosyl) methyl acetoacetate, since the maximum is at 232  $m\mu$  and the rotation is normal.

TABLE IV  
ULTRAVIOLET ABSORPTION OF ENOL GLYCOSIDES OF METHYL ACETOACETATE IN WATER

Compound	Wave length max., $m\mu$	Mol. ext. coeff. $\epsilon \times 10^{-4}$
Glucoside III ( <i>trans</i> )	236	1.509
IV ( <i>cis</i> )	232	1.445
Galactoside VII ( <i>cis</i> )	233	1.396
VIII ( <i>trans</i> )	236	1.445
Cellobioside XI ( <i>cis</i> )	232	1.425
XII ( <i>trans</i> )	236	1.491
Xyloside XIV ( <i>cis</i> )	232	1.389

As previously described, the enol glucoside synthesis employs the Koenigs-Knorr conditions with the addition of a trace of an amine.<sup>2</sup> The amine catalyst used in the first syntheses of the acetoacetic ester type glucosides was quinoline. Other amines can be advantageously substituted for quinoline (see Table V). Benzylamine has been found to be generally better than quinoline, and was used in all syntheses reported here. Its use led to crystalline products in some reactions in which quinoline gave uncrystallizable sirups. There was no correlation between basicity of the amine and its effectiveness, nor could differences be observed in the action of primary, secondary or tertiary amines. Those amines which gave the

(12) Dr. Pigman stated in ref. 7 (1944) that "apparently all known unacetylated  $\beta$ -D-glucosides are levorotatory."

(13) Rusoff, Platt, Klevens and Burr, THIS JOURNAL, 67, 673 (1945).

shortest reaction time generally produced sirups with the best crystallizing properties.

TABLE V  
EFFECTIVENESS OF AMINES IN PROMOTING THE ENOL  
GLYCOSIDE SYNTHESIS

Amine	$pK$	Time to react, hr.	Yield, <sup>a</sup> g.	
			<i>trans</i> m. p. 132°	<i>cis</i> m. p. 125°
None	.....	Incomplete	None	None
Aniline	$4.6 \times 10^{-10}$	106	None	None
Quinoline	$1 \times 10^{-9}$	24	0.95	0.35
Phenylhydrazine	$1.6 \times 10^{-9}$	72	None	None
Pyridine	$2.3 \times 10^{-9}$	24	1.0	0.60
Dibenzylamine	$1 \times 10^{-6}$	15	1.6	.70
Benzylamine	$2.4 \times 10^{-6}$	15	1.7	.90
Trimethylamine	$7.4 \times 10^{-5}$	20	0.80	None
Dimethylamine	$7.4 \times 10^{-4}$	60	.30	None
Methylamine	$5 \times 10^{-4}$	20	None	None
Cyclohexylamine	$1 \times 10^{-4}$	15	2.5	0.40
Piperidine	$1.6 \times 10^{-3}$	50	1.2	.10

<sup>a</sup> From 10 g. tetraacetyl- $\alpha$ -D-glucosyl bromide and an excess of the aglucon as described in the experimental section.

The condensation of glucose with acetoacetic ester in the presence of zinc chloride proceeds with the formation of a substituted furan (XXX).<sup>14,15</sup> It has been suggested that an intermediate in this condensation may be an enol glucoside of the  $\beta$ -ketoester (XXVIII).<sup>15</sup> Gonzalez attempted to

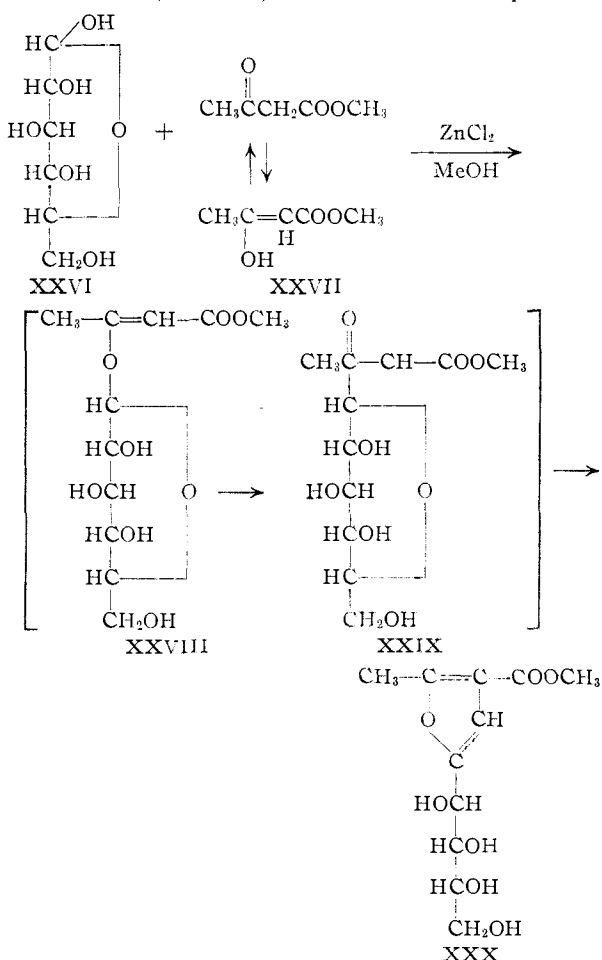

(14) West, *J. Biol. Chem.*, **74**, 561 (1927).

(15) Gonzalez and Aparicio, *Anales fs. y quim.*, **41**, 846 (1945).

synthesize this possible intermediate to ascertain if it could be converted to the furan derivative, but he was not successful. The condensation of tetraacetyl- $\alpha$ -D-glucopyranosyl bromide with the sodium salt of ethyl acetoacetate gave only a small amount of an unidentified material.<sup>15</sup> Since the enol glucosides are now available, it seemed of interest to test the Gonzalez hypothesis. When III was treated with zinc chloride under the conditions of the reaction reported by West<sup>14</sup> and Gonzalez, the starting material was recovered in a high yield, indicating no appreciable rearrangement.

### Experimental

**Preparation of *trans* and *cis*-O-(Tetraacetyl- $\beta$ -D-glucopyranosyl Methyl Acetoacetate (I and II).**—A mixture of 50 g. (0.12 mole) of tetraacetyl-D-glucopyranosyl bromide, 100 g. (0.86 mole) of methyl acetoacetate and 50 g. of Drierite was shaken in 400 ml. of dry ether with 17.5 g. (0.15 equiv.) of silver oxide and 30 drops of benzylamine. The bromide ion test became negative in fifteen hours.

The solids were removed by filtration and the ether by distillation at reduced pressure. The excess keto ester was removed by distillation at 1 mm. pressure and a bath temperature of 65°. The light orange sirup obtained was dissolved in 50 ml. of dry ether and the solution was left at room temperature until crystallization started (one hour). It was then stored in a refrigerator at 5° for 24 hours. A solid mass of crystals formed, which was collected and washed with ether. The yield was 13 g. of long, colorless needles, which were recrystallized from 60% ethanol. The product (I) melted at 132–133.5°, and showed  $[\alpha]^{25D} -26.6^\circ$  (*c*, 3, chloroform). The analysis is in Table I.

A good procedure for the separation of the *cis* form could not be devised. When the filtrate from the first crop of crystals (I) was diluted to 200 ml. with ether and left in the refrigerator at 5° for a week, the *cis* form (II) slowly crystallized in a granular form or as rosettes of heavy needles. It was usually contaminated with some of the *trans* form (slender needles), and if this contamination was considerable, purification of II by recrystallization was very difficult. When the amount of impurity was small, recrystallization from methanol gave 3–4 g. of pure II which melted at 125–126°, and showed  $(\alpha)_D -23.7^\circ$  (*c*, 2.5, chloroform). The analysis is in Table I.

Compounds I and II were separated by chromatography on Silene EF<sup>16</sup> as described previously for similar derivatives.<sup>2</sup> This was the best method for obtaining pure II. The  $\beta$ -D-galactopyranosides and  $\beta$ -D-xylopyranoside were produced by procedures almost identical to that described above, except that different solvents were used as indicated in Table I.

**Conversion of I and II to Methyl  $\beta$ -Hydroxybutyrate  $\beta$ -D-Glucopyranoside Tetraacetate (XV).**—The catalytic reduction of the *cis-trans* enol glucosides was carried out as reported previously.<sup>2</sup> When 1.0 g. of I was shaken with 0.5 g. of palladium catalyst in 50 ml. of absolute ethanol at atmospheric pressure, 59 ml. of hydrogen was absorbed in one hour. The theoretical uptake required to saturate the enol double bond was 56 ml.

The reaction mixture yielded 0.3 g. of a crystalline product which was recrystallized from ether. The melting point was 80–81°,  $[\alpha]^{25D} +2.0^\circ$  (*c*, 5, chloroform).

*Anal.* Calcd. for C<sub>19</sub>H<sub>25</sub>O<sub>12</sub>: C, 50.90; H, 6.25. Found: C, 51.00; H, 6.35.

A similar reduction of II yielded a product which melted at 79.5–81.5°, and gave no depression of the melting point when mixed with the reduction product of I. It showed  $[\alpha]^{25D} +2.5^\circ$  (*c*, 5, chloroform).

*Anal.* Calcd. for C<sub>19</sub>H<sub>25</sub>O<sub>12</sub>: C, 50.90; H, 6.25. Found: C, 50.80; H, 6.27.

The conversion of I and II by saturation of the enol double bond to the same glucoside of methyl  $\beta$ -hydroxybutyrate establishes that they both have the same configuration on the anomeric carbon atom. Because of the method of synthesis and the rotations of the derivatives, this configuration is probably beta.

(16) Binkley and Wolfrom, Scientific Report Series No. 10, Sugar Research Foundation, Inc., New York, N. Y., 1948.

**Preparation of *cis* and *trans*-O-(Heptaacetyl- $\beta$ -cellobiosyl) Methyl Acetoacetate (IX and X).**—Due to the low solubility of heptaacetylcellobiosyl bromide in ether it was necessary to use a large excess of the aglycon as the solvent. To 34.0 g. of heptaacetylcellobiosyl bromide, 160.0 ml. of methyl acetoacetate, 30 g. of Drierite and 100 ml. of ether was added 15.0 g. of silver oxide and 30 drops of benzylamine. The reaction was complete after shaking for 12 hours. The mixture was worked up as described above for the preparation of I and II.

A product crystallized spontaneously upon removal of the excess aglycon. The crystalline sirupy mass was dissolved in 200 ml. of boiling methanol, and the solution was left in the refrigerator for six hours during which time crystallization occurred. The fine needles were collected and washed with 100 ml. of methanol. Upon recrystallization from 250 ml. of methanol, 10.0 g. of IX which melted at 188–193° was obtained. Three more recrystallizations from methanol gave *m. p.* 194–196°,  $[\alpha]^{25}_D -30.1^\circ$  (*c*, 1, chloroform).

The sirupy filtrate from above was concentrated *in vacuo* to a thick sirup, which was then diluted with 50 ml. of absolute ethanol. It was left at room temperature for a week, during which time a hard crystalline layer formed on the wall of the flask. The supernatant liquid was decanted, the crystals washed with absolute ethanol, and then recrystallized from the same solvent. Five grams of X was obtained which melted at 187–188° and showed  $[\alpha]^{25}_D -25.7^\circ$  (*c*, 2, chloroform).

Compounds IX and X were shown to possess identical anomeric configurations by the same procedure used to relate I and II. Reduction of IX produced a heptaacetyl- $\beta$ -cellobioside of methyl  $\beta$ -hydroxybutyrate (XVI), which after three recrystallizations from methanol and two from ether, melted at 168–170° and showed  $[\alpha]^{25}_D -19.5^\circ$  (*c*, 1, chloroform).

*Anal.* Calcd. for  $C_{31}H_{44}O_{20}$ : C, 50.48; H, 5.97. Found: C, 50.60; H, 6.12.

Reduction of X gave the same derivative, *m. p.* 168–171°;  $[\alpha]^{25}_D -19.0^\circ$  (*c*, 1, chloroform). A mixture of the two reduction products melted with no depression.

*Anal.* Calcd. for  $C_{31}H_{44}O_{20}$ : C, 50.48; H, 5.97. Found: C, 50.20; H, 6.08.

The difficulty of obtaining XVI in a pure form indicates that the reduction gave crystalline heptaacetyl-cellobiosides of both *D*- and *L*-methyl  $\beta$ -hydroxybutyrate.

**Deacetylations.**—The catalytic barium methoxide method was used. Four grams of V was dissolved in 200 ml. of dry methanol. The rotation of this solution was  $-0.24^\circ$  (1 dcm.). Upon addition of 2.0 ml. of 0.40 *N* barium methoxide the rotation changed rapidly and reached a constant value of  $-0.92^\circ$  (1 dcm.) in ten minutes.

Thirty minutes after initiation of the reaction 7.0 ml. of 0.115 *N*  $H_2SO_4$  was added, and the barium sulfate was removed by filtration through an asbestos mat. The filtrate was concentrated *in vacuo* at 50° to a sirup which crystallized spontaneously. The yield was 2.2 g., 90%. Two recrystallizations from absolute ethanol gave slender needles melting at 188–189°,  $[\alpha]^{25}_D -73.7^\circ$  (*c*, 2, water). The analysis is in Table I.

**Periodate Oxidations.**—About 0.22 g. of the deacetylated glycoside was made up to 10 ml. in a volumetric flask with approximately 0.3 *M* sodium periodate (5% excess of the amount required for the oxidation). A sample was transferred to a polarimeter tube and the rotation recorded periodically until it became constant. The results are shown in Fig. 1.

**Effect of Temperature on Specific Rotation.**—The determinations of specific rotation were made with a Schmidt and Haensch polarimeter No. 52-b with monochromator in a 2-decimeter jacketed tube with water as the circulating fluid. The tube contained a well for immersion of a thermometer. Correction was made for liquid density change with temperature.

**Effectiveness of Amines in Promoting the Enol Glycoside Synthesis.**—A mixture of 10 g. of tetraacetyl- $\alpha$ -D-glucopyranosyl bromide, 20 g. of methyl acetoacetate and 10 g. of Drierite in 100 ml. of absolute ether, plus 4 g. of silver oxide and 8 drops of the amine under investigation was shaken until the reaction was complete. The mixture was worked up as described above. The yields of unrecrystallized products are given in Table IV.

**Acknowledgment.**—We wish to thank Professor S. M. McElvain, University of Wisconsin, for his

suggestions concerning the electronic interpretations presented in this paper, and Professor W. W. Pigman, Medical College of Alabama, Birmingham, and Dr. H. S. Isbell, National Bureau of Standards, Washington, D. C., for reviewing this manuscript prior to submission to the Editor.

### Summary

The synthesis of the *cis-trans* enol glycosides of methyl acetoacetate from the fully acetylated glycosides is described. The latter compounds were prepared by the Huebner modification of the Robertson method, employing specifically the Koenigs-Knorr conditions with the addition of a trace of an amine catalyst (quinoline). An investigation was made substituting other amines for quinoline, and included ten aromatic, aliphatic, primary, secondary and tertiary amines of *pK* values from  $4.6 \times 10^{-10}$  to  $1.6 \times 10^{-8}$ . No correlation was found between the type of amine or the *pK* and its effectiveness in promoting the reaction. Benzylamine is superior to quinoline or the other amines tested in that it gives the best yields of both the *cis* and *trans* forms.

The configurations of the aglycon in the *cis-trans*  $\beta$ -D-glucoside pair were related to those of the  $\beta$ -D-galactosides by periodate oxidation. On destruction of the asymmetry due to carbon atoms 2, 3 and 4 the same dialdehyde (corresponding to *L*'-methoxy-D-hydroxymethylidiglycolic aldehyde formed in periodate oxidation of methyl  $\beta$ -D-glucopyranoside) was obtained from the *cis*- $\beta$ -D-glucoside and the *cis*- $\beta$ -D-galactoside. The *trans* forms were related in a similar manner by conversion to the corresponding isomeric dialdehyde.

Absolute configurations were assigned to the *cis-trans*  $\beta$ -D-glycosides on the basis of studies which indicate intramolecular interaction in one of the forms. One member of each *cis-trans* pair has an abnormal rotation in water and an unusually high temperature coefficient. This abnormality disappeared in solvents of low polarity (dioxane, acetic acid). The unusual dextrorotation shown by these forms was rationalized on the basis of intramolecular hydrogen bonding. Resonant structures are proposed that would be stabilized in a nucleophilic solvent. Inspection of Hirschfelder molecular models of the *cis* and *trans* forms indicates that spatial relationships of the atoms in the aglycon would favor bonding in one of the forms and make it unlikely in the other.

The *cis* and *trans* compounds exhibited ultraviolet absorption maxima that differed by 30–40 Å. units. Those assigned *cis* configurations had a maximum at 232  $m\mu$ . while the *trans* forms had a maximum at 236  $m\mu$ .

The condensation of glucose with acetoacetic ester proceeds with the formation of a substituted furan

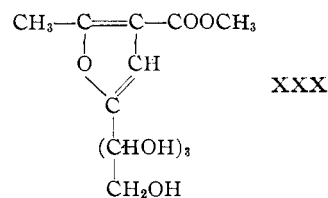

An enol glucoside of acetoacetic ester has been proposed as an intermediate in the formation of the product. *trans*-O-( $\beta$ -D-Glucopyranosyl) methyl acetoacetate (III) resisted rearrangement on re-

fluxing with zinc chloride in methanol, a fact which indicates that a derivative of this type is probably not an intermediate in the formation of XXX.

MADISON, WISCONSIN

RECEIVED JUNE 22, 1950

[CONTRIBUTION FROM THE DEPARTMENT OF BIOCHEMISTRY, UNIVERSITY OF WISCONSIN]

## Reductive Cleavage of Benzyl Glycosides for Relating Anomeric Configurations. Preparation of Some New Benzyl Pentosides<sup>1</sup>

BY CLINTON E. BALLOU, SAUL ROSEMAN<sup>2</sup> AND KARL PAUL LINK

Conditions for the reductive cleavage of acetylated benzyl glycosides which permit isolation of the unmutarotated 1-hydroxy acetylated aldoses are given. The reduction is effected with palladium and hydrogen in a neutral inert solvent (ethyl ether). Cleavages of benzyl  $\alpha$ -D-xylopyranoside triacetate to 2,3,4-triacetyl- $\alpha$ -D-xylopyranose, and of benzyl  $\beta$ -D-xylopyranoside triacetate to 2,3,4-triacetyl- $\beta$ -D-xylopyranose were accomplished with isolation of the products in a pure, crystalline form. Similar conversions were made with the D-glucopyranosides as well as with D- and L-arabinopyranosides. The products when crystalline were obtained in a yield of 70 to 90%, and in a high state of purity.

These transformations have a special significance with respect to the classical enzymatic experiments of Armstrong used in relating anomeric configurations of methyl D-glucosides and D-glucose. The possibility of inversion of configuration during enzymatic hydrolysis has never been disproved. However, the reductive cleavage of benzyl glycosides offers no opportunity for inversion, and relates anomeric configurations of the acetylated benzyl glycosides and the 1-hydroxy acetylated aldoses in a conclusive manner. This chemical conversion affords a complete substantiation of the classification of anomeric forms of the acetylated glycosides and the corresponding polyacetyl 1-hydroxy aldoses proposed by Hudson.

For the purpose of this investigation the following new pentosides were made: benzyl  $\alpha$ - and  $\beta$ -D-xylopyranoside; benzyl  $\alpha$ - and  $\beta$ -D-xylopyranoside triacetate; benzyl  $\alpha$ - and  $\beta$ -D-arabinopyranoside; benzyl  $\alpha$ - and  $\beta$ -D-arabinopyranoside triacetate; and benzyl  $\alpha$ -L-arabinopyranoside, benzyl  $\alpha$ -L-arabinopyranoside triacetate, and benzyl  $\beta$ -L-arabinopyranoside triacetate.

The classical experiments of Armstrong<sup>3</sup> on the enzymatic cleavage of methyl glucosides form an experimental cornerstone on which the anomeric configurations of the glucosides and free glucose are related. Armstrong presented evidence that methyl  $\alpha$ -D-glucopyranoside and methyl  $\beta$ -D-glucopyranoside have the anomeric configurations, respectively, of  $\alpha$ - and  $\beta$ -D-glucose.

The periodate oxidation studies of Jackson and Hudson<sup>4</sup> in 1937 extended this relationship to include other methyl glycosides. They established the anomeric configurations of several methyl aldohexopyranosides with respect to the two methyl D-glucopyranosides. Thus, if the evidence presented by Armstrong<sup>3</sup> be accepted without reserve, the anomeric configurations of the methyl hexopyranosides (and probably the glycosides in general) have been satisfactorily related to the  $\alpha$ - and  $\beta$ -forms of D-glucose.

However, there is cause to reconsider the data presented by Armstrong.<sup>3</sup> Briefly described, he treated the two methyl D-glucopyranosides with the appropriate enzymes, and followed the hydrolyses polarimetrically. He remarked, "As a glucose of high initial rotatory power was obtained from  $\alpha$ -methyl glucose, and one of low initial rotatory power from the  $\beta$ -glucoside, it is clear that  $\alpha$ -

and  $\beta$ -glucose correspond, respectively, to the  $\alpha$ - and  $\beta$ -glucoside."

This conclusion is valid if one assumes that enzymatic cleavage occurs without inversion of anomeric configuration. The mechanism of enzymatic hydrolysis of the glycosidic linkage has not been established, but it is apparent that the possibility of inversion will depend on which bond is cleaved. Thus, inversion could occur only if the hydrolysis proceeds by reaction II. Recent studies

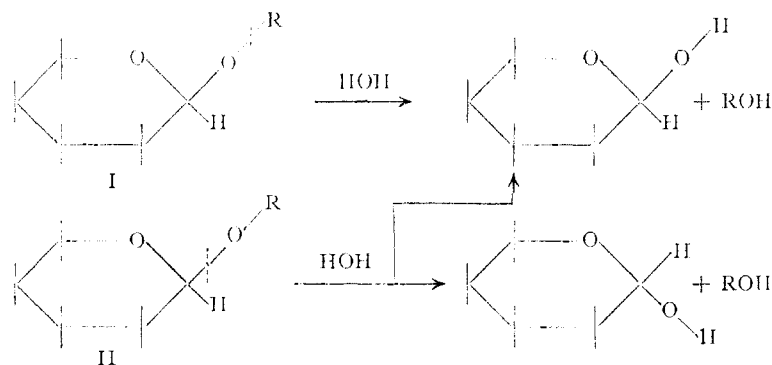

in this Laboratory on the alkaline methanolysis of certain alkali-sensitive glucosides<sup>5,6,7</sup> have revealed that methanolysis may occur on either side of the glucosidic oxygen, depending on the nature of the aglucon. The point of enzymatic cleavage might likewise vary depending on some similar but unknown factors, and the possibility of inversion might exist. Cohn<sup>8</sup> has demonstrated cleavages of both reaction types I and II on D-glucose-1-phosphate by phosphatases and phosphorylases. These occurred without apparent

(1) Published with the approval of the Director of the Wisconsin Agricultural Experiment Station. Supported in part by the Research Committee of the Graduate School from funds supplied by the Wisconsin Alumni Research Foundation. This paper is part of the Doctorate Thesis submitted by Clinton E. Ballou to the Faculty of the Graduate School of the University of Wisconsin, January 1950.

(2) Bobs Roberts Memorial Hospital for Children, The University of Chicago, Chicago, Illinois.

(3) Armstrong, *J. Chem. Soc.*, **83**, 1305 (1903).

(4) Jackson and Hudson, *This Journal*, **59**, 994 (1937).

(5) Huebner, Karjala, Sullivan and Link, *ibid.*, **66**, 906 (1944).

(6) Spero, Ballou and Link, *ibid.*, **71**, 3740 (1949).

(7) Ballou and Link, *ibid.*, **71**, 3743 (1949).

(8) Cohn, *J. Biol. Chem.*, **180**, 771 (1949).